

WD-40®

INDUSTRIALSOLUTIONS



MAINTENANCE OF ELECTRICAL AND PNEUMATIC TOOLS



WD-40® Multi-Use Product is a high-efficiency maintenance agent for metal products. It exhibits very strong surface affinity with metal. Its deep-penetrating solution is able to effectively remove oil, impurities and moisture on metal surfaces, leaving a dense anti-rust film which lubricates and protects, keeping surfaces clean and lubricated. Recommended by major electrical tools brands for maintenance use.

1. Maintaining pneumatic tools

Cleans and protects from corrosion the surfaces of pneumatic screwdrivers, pneumatic wrenches, gas nail guns, pneumatic drills, pneumatic shear products and pneumatic sanding tools.

2. Maintenance of electrical tools

Lubricates drill chucks and drill caudal peduncles, cleans the surface of electrical tools, lubricates and cleans rotor commutators and many others.

WD-40 MULTI-USE PRODUCT

It's the product you know and trust, with more than 65 years of proven performance. Our Multi-Use Product is the most recognized and relied upon name in its class — protecting equipment from rust and corrosion, penetrating stuck parts, displacing moisture and lubricating almost anything. It's now available in a variety of delivery and application methods, along with other innovations, making jobs easier, safer and more efficient.

- WD-40 Multi-Use Product
- WD-40 EZ-REACH®
- WD-40 20 Liters
- WD-40 Smart Straw®
- WD-40 4 Liters
- WD-40 208 Liters



YOU KNOW THE WD-40® BRAND NAME...

BUT DO YOU KNOW ALL IT CAN DO FOR YOUR MRO JOBS?

Our time-tested formulas have been solving problems across a variety of industries for more than 65 years.

PROVEN AND EFFECTIVE FORMULAS FOR TOUGH ENVIRONMENTS

Lab testing shows that WD-40 Brand products outperform other brands in critical performance tests for dependability and value you can count on.

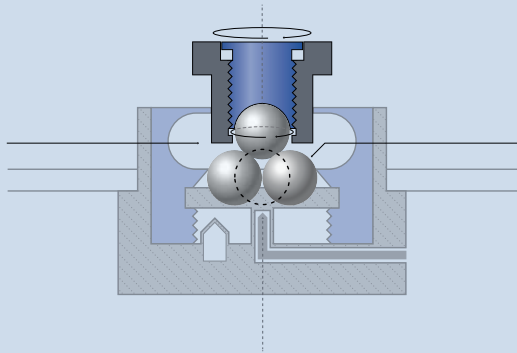

REDUCE DOWNTIME AND PROTECT YOUR FACILITY'S ASSETS

WD-40 Brand products help protect assets to promote longer equipment life, prevent unscheduled downtime due to unexpected equipment failure, and help avoid accidents and injuries caused by poorly maintained equipment.

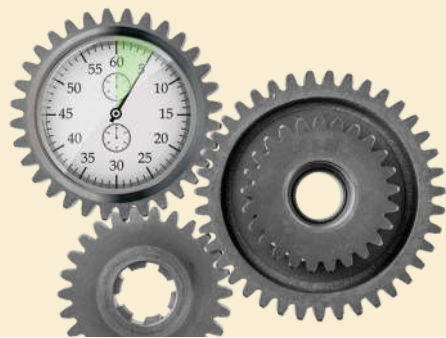

SAFETY AND COMPLIANCE ARE OUR TOP PRIORITIES

All WD-40 Brand products are formulated to minimize the risk of harm to people, surfaces and the environment. ¹ Our safer product formulations do not require warnings for cancer, birth defects or other reproductive harm.



INDUSTRY-LEADING, INNOVATIVE SOLUTIONS MAKE YOUR JOB EASIER

WD-40 Brand has been a trusted name in maintenance products for more than 65 years. We strive to continuously improve and innovate with products designed to tackle any challenge.



From metal fabrication operations to property management, maintenance, repair and operation (MRO) pros can count on WD-40 Brand products to keep their facilities running with versatile delivery and application methods that offer a unique combination of safe, powerful and specialized formulas designed to increase efficiency, reduce downtime and minimize risk—everything you need to get the job done right.

¹ When used and disposed of as directed.



SUPERIOR PERFORMANCE

BORN FROM ROCKET SCIENCE™



CLEANERS AND DEGREASERS

Engineered to be both powerful and safe. Our Safer Choice Certified Cleaner & Degreaser keeps facilities and equipment running smoother and looking like new.

CONTACT CLEANER FAST DRYING

- Fast acting, non conductive cleaner
- Penetrates quickly and leaves no residue
- For use on electrical equipment, contacts and plastic

APPLICATIONS

- Circuit Boards
- Switches
- Printers
- Controls
- Copiers
- Electrical Assemblies
- Tape Heads
- Precision Instruments



DEGREASER FOAMING SPRAY

- Removes grease, oil, fat, dirt, soap scum & grimy residues
- Power foam works immediately on contact
- Easy to rinse, leaves no residue

APPLICATIONS

- Engines
- Hand Tools
- Lifts & Hoists
- Industrial Machinery
- Work Surfaces
- Flooring
- Exhaust Hoods



THROTTLE BODY, CARB & CHOKE CLEANER FAST-ACTING

- Cleans gum, dirt, varnish, lead & carbon deposits
- Eliminates hard starting, rough idling & stalling
- Reduces emissions and fumes

APPLICATIONS

- Carburetors
- Throttle Body
- Choke
- Gas-powered Equipment
- Fleet Maintenance
- Non-painted Metal Parts



BRAKE & PARTS CLEANER NON-CHLORINATED

- Removes oil, grease, dirt and brake fluid
- Cleans without disassembling the unit
- Safe to use on brake linings, pads and drums

APPLICATIONS

- Disc Brake
- Brake Drum
- Brake Calipers



MACHINE & ENGE DEGREASER DEEP PENETRATION

- Removes tough grease, oil, dirt & grime
- Fast acting
- Easy to wipe off and rinse with water

APPLICATIONS

- Engine
- Stroke Engine
- Industrial Machinery



AIR DUSTER DUST FREE

- Dry powerful blast, removes dust easily
- Safe on all plastics & delicate precision equipment
- Non-abrasive, non-corrosive, residue free

APPLICATIONS

- Camera
- Printers
- Laptop
- Computers
- Keyboards
- Photo Equipment
- Fax Machines
- Copiers
- Telephones
- Lab Equipment
- Scientific Equipment
- Vacuums
- Watches
- Stereos
- Scanners
- Clocks



AIR CONDITIONER CLEANER FOAMING SPRAY

- 99.999% anti-bacterial*
- No need to rinse off
- Safe on AC fins & coils
- Professional result in minutes

*Kills 99.999% of *Staphylococcus aureus*, *Escherichia coli* and *Candida albicans* in 5 minutes; and 99.999% of *Aspergillus brasiliensis* in 15 minutes.

APPLICATIONS

- AC Fins
- AC Coils



LUBRICANTS

We offer an assortment of fast-acting, high-performance lubricants that are proven to withstand tough industrial environments. They'll keep parts moving and reduce unplanned downtime, while helping to ensure facility safety.

SILICONE QUICK-DRYING

- Prevents parts from sticking
- Waterproofs & protects against moisture
- Lubricate, free seals, restore hardened rubber

APPLICATIONS

- Belt
- Bearing
- Linkages
- Tools
- Pulleys
- Guide Rails
- Locks
- Doors & Hinges
- Valves
- Hoists
- Conveyors
- Pipes
- Compression & Injection Mouldings



DRY LUBE WITH PTFE

- Enhanced lubrication & protection
- Dry PTFE film that resists dirt,dust and oil
- For use on metal, plastic & glass

APPLICATIONS

- Blades & Drill Bits
- Gears
- Locks
- Tracks
- Chains
- Hinges
- Power Tools & Equipment



WHITE LITHIUM GREASE LONG-LASTING

- Water and heat resistant lubricant
- Long lasting protection against rust & corrosion
- High viscosity grease

APPLICATIONS

- Water Pumps
- Hinges
- Chains
- Pistons
- Conveyors
- Metal Parts
- Catches
- Cables
- Runners
- Motor Pivot Points
- Overhead Door Tracks
- Gear & Brake Mechanisms
- Bearings
- Winches
- Latches



FOOD GRADE SILICONE COLOURLESS

- NSF® Certified: H1 and H2 Registration
- Designed for food industry handling application & food processing
- Colorless, odorless, non-staining film

APPLICATIONS

- Food Racks
- Pins
- Guides Rail
- Castors
- Linkages
- Pulleys
- Conveyor Belts
- Coin Mechanisms
- Bottling Machinery
- Plastic Rollers & Gears
- Vending Machines
- Rubber Mountings & Seals
- Food Processing & Handling Equipment
- Rings
- Chutes
- Slicers
- Freezers
- Locks
- Timers
- Tools



CUTTING OIL MULTI-PURPOSE

- Improves machine finishes and extends tool life
- Reduces cutting torque and improves cutting efficiency
- Suitable for use on all metals

APPLICATIONS

- Reaming Processes
- Cutting
- Drilling
- Milling
- Tapping
- Threading
- Sawing
- Shearing
- Turning



CHAIN LUBE ANTI-FLING

- Outstanding anti-fling properties
- Superior anti-wear and penetration
- Suitable for street and off-road riding
- O,X,Z ring compatible

APPLICATIONS

- Chain
- Drivetrain
- O,X,Z Ring



BELT DRESSING ANTI-SLIP

- Eliminate squeaking and slipping
- Restore belts pliability and flexibility
- Extends belt life

APPLICATIONS

- V Belt
- Flat Belt
- Cogged Belt



GEL LUBE NO-DRIP

- Thick, no drip, no mess, non-fling
- Stays where you spray it; perfect for vertical surfaces
- Self-healing characteristics

APPLICATIONS

- Chains
- Cables
- Gears
- Rollers
- Bearings
- Moving Parts
- Vertical Surfaces



RUST MANAGEMENT

Preventing and removing rust is an important part of facility and equipment maintenance, repair and operations. Whether it's to prevent or remove rust, we have a product for the job.

CORROSION INHIBITOR LONG-LASTING

- Vapor corrosion inhibitors seal and protect to block corrosion
- Works indoors and outdoors
- Protects metals up to two years
- NSF Certified: A7 Registration

APPLICATIONS

- Equipment And Metal Parts Subjected To Extended Storage Periods
- Machine Surfaces
- Tools
- Chains
- Cables
- O,X,Z Ring



RUST REMOVER SOAK DISSOLVES RUST SAFELY

- Safely removes tough rust from metal parts & tools
- Ideal for restoring rusted parts to bare metal
- Non-toxic, acid free, biodegradable

APPLICATIONS

- Rusted Metal Surfaces



OTHER WD-40 COMPANY BRANDS

No matter the maintenance need, we have a product to make any job easier. WD-40 Company's other great products are made tough enough for any industrial environment.

3-IN-ONE® Professional AIR-CONDITIONER CLEANER is a water-based cleaner that gives you triple the benefits and leaves your indoor summer breeze all day long.



Take a look at our full product offerings to see how we've expanded and enhanced our industrial-strength products.